

Hudson Kids Table & Stools

Assembly Instructions

mocka

Thank you for your purchase.
Please follow the instructions below for correct assembly.

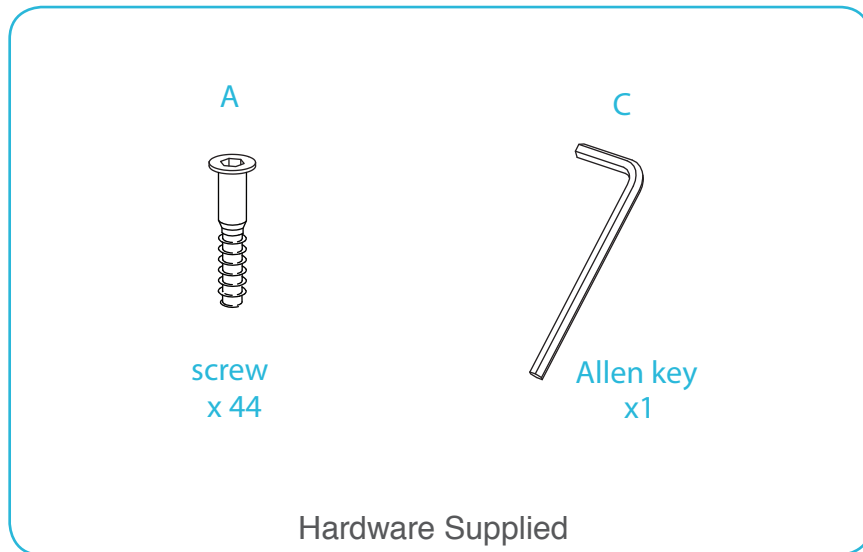

Once fully assembled please ensure all legs are sitting flush against the table/stool underside to ensure stability. Do not over-tighten screws.

The recommended age for this set is 2-6 years.
The weight limit on the stools is 70kg.

To ensure longevity of the wood please use a damp cloth only for cleaning. Avoid use of household cleaners.

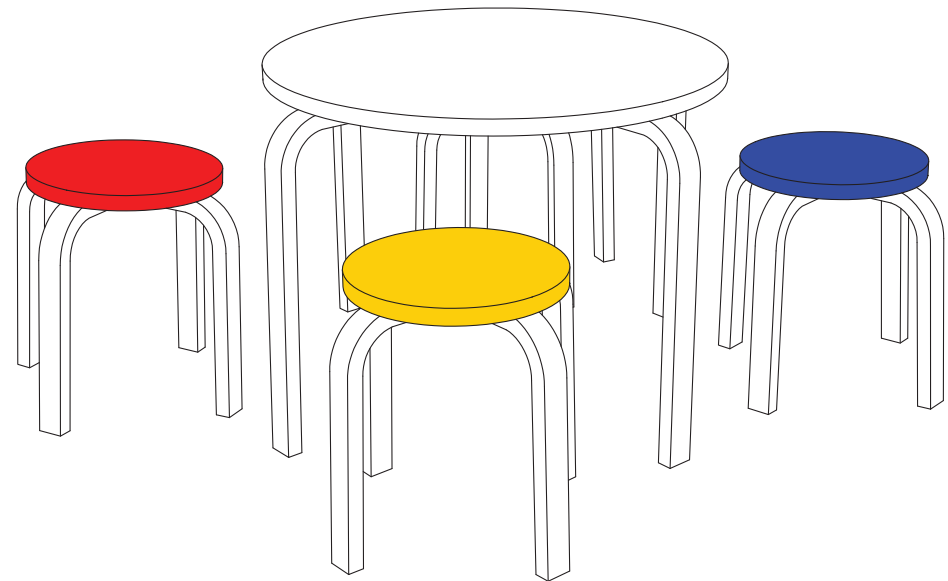

Hudson Kids Table & Stools

Assembly Instructions

mocka

1 Table

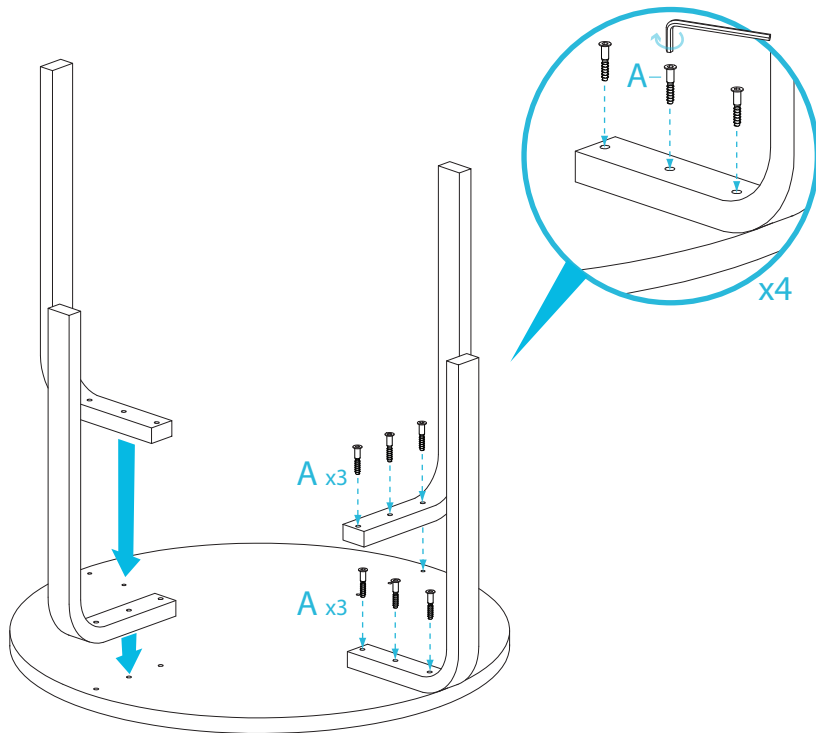

Find all four table legs and position them on the underside of the table top. Using 3x screws (A) and the allen key (B) attach each leg to the table top.

2

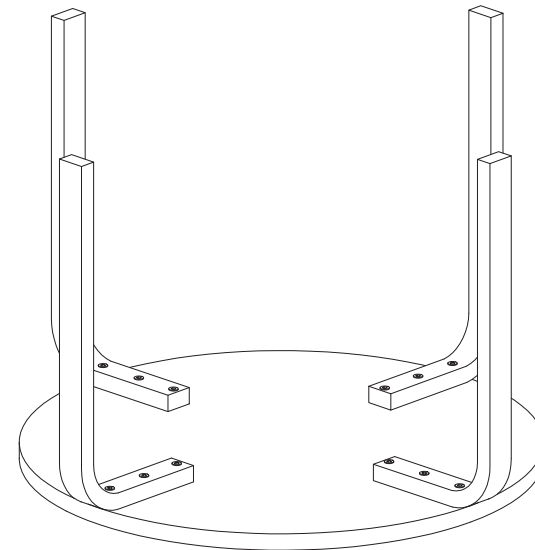

Fasten all screws and ensure all legs are sitting flush with the table underside to ensure stability. Flip table over and it is ready for use.

Hudson Kids Table & Stools

Assembly Instructions

mocka

3 Stools x4

4

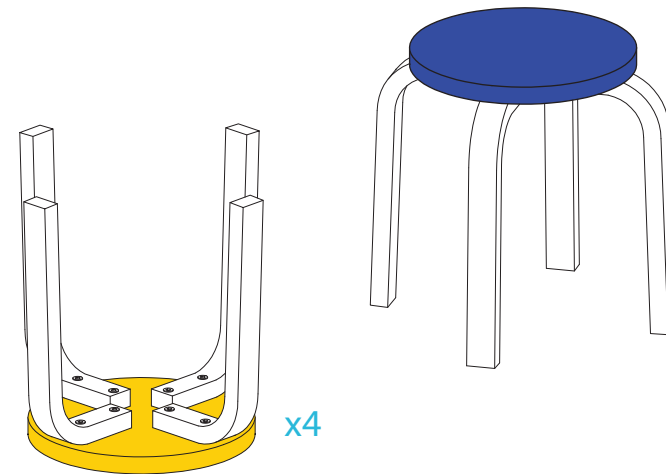
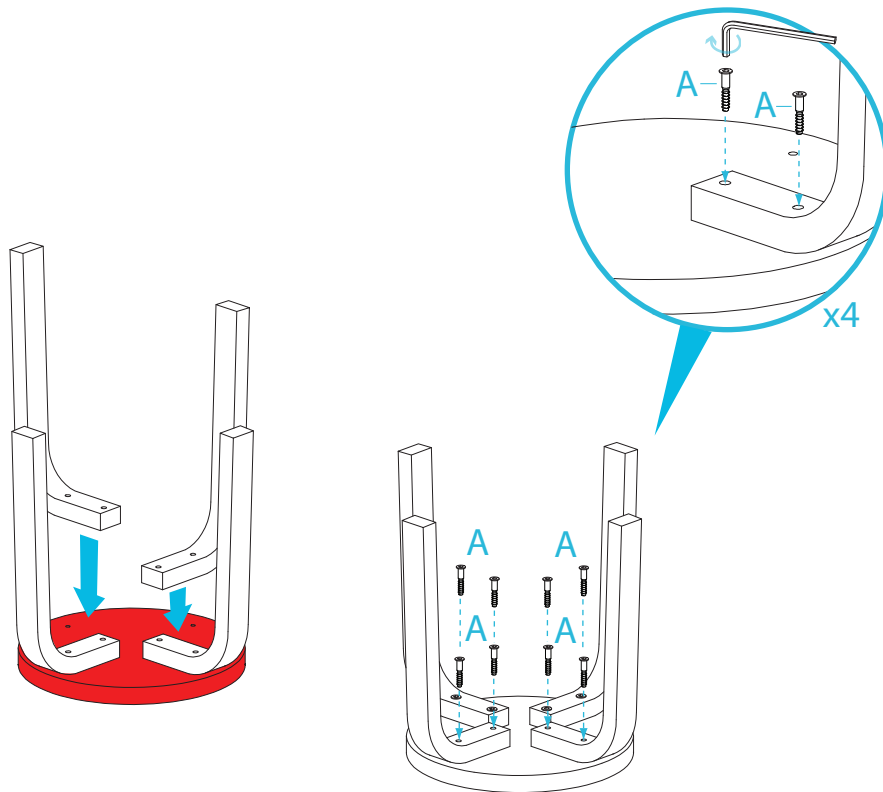

Find one round seat piece and four stool legs. Attach each leg to the underside of the seat using 2x screws (A) in each and tightening with the allen key (B). Ensure all four legs are securely fastened.

Repeat Step 3 to assemble the next three stools. Ensure all screws are fastened and legs sit flush with underside of the seats. Regularly check all screws are secure but not overly tightened. All done, enjoy!