

# Rookie Bike

## Assembly Instructions

Thank you for your purchase.  
Please follow the instructions below for correct assembly.

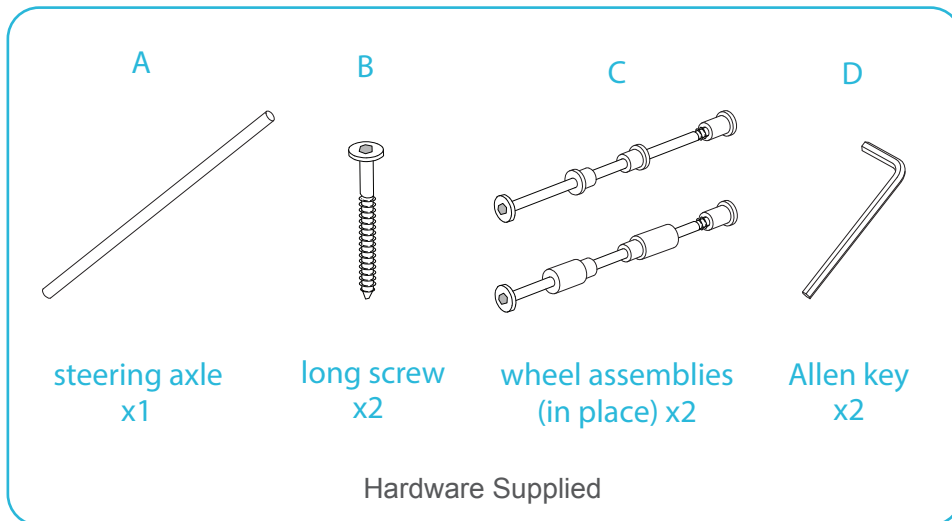

Mocka Balance Bikes are designed for children aged 2-6 years. These bikes should not be used on public roads or near traffic. Wearing a helmet is advisable. Only one child at a time should use the bike. Recommended for children under 35 kg.

Adult supervision is strongly recommended at all times. Ensure your child is confident at braking and is aware of road rules & safety. All screws, steering and axles must be checked by an adult before use.

Please keep your bike protected from water and moisture. Due to the wooden nature of the bike, they should not be left outside for long periods of time and should be dried down after use. We recommend storing your bike inside when not in use. Clean with a damp cloth - do not use chemical spray cleaners.

# mocka



All nuts and bolts must be checked and tightened before first use. Regularly check all screws are tight to ensure safety.

# Rookie Bike

## Assembly Instructions

mocka

1

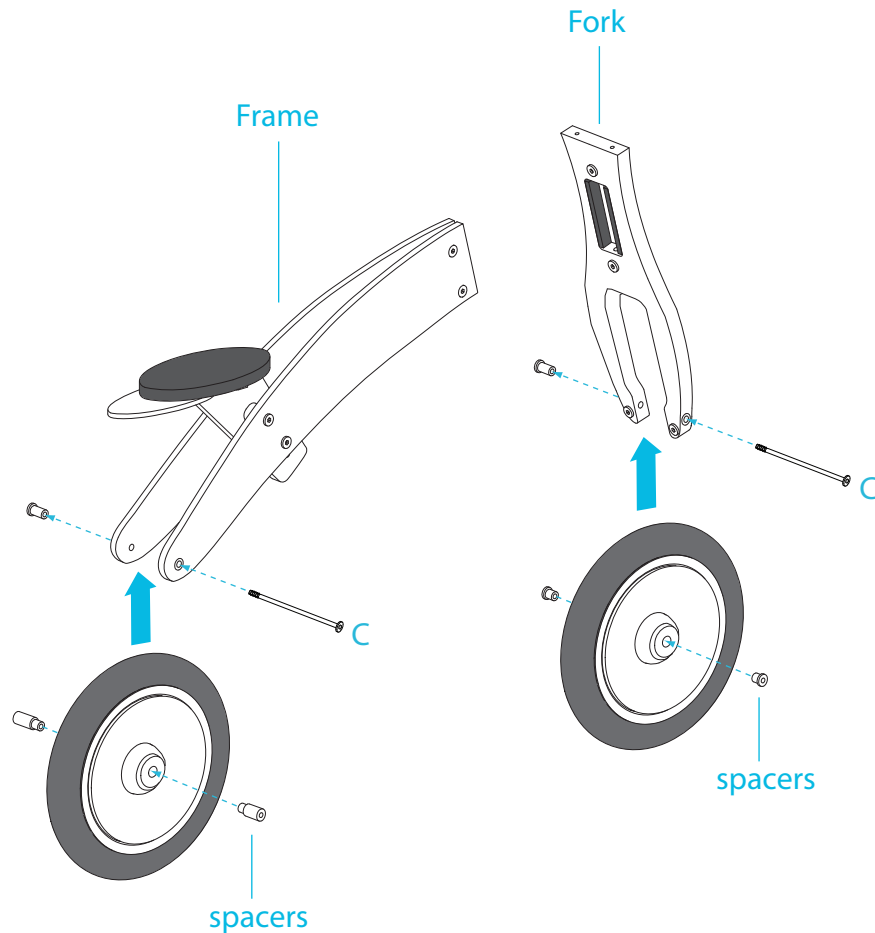

Firstly separate wheel assemblies (C) and insert plastic spacers into both wheels as shown. Slide bike wheels into position and attach to both the frame and fork using the bolts and nuts. Tighten with Allen key (D).

2

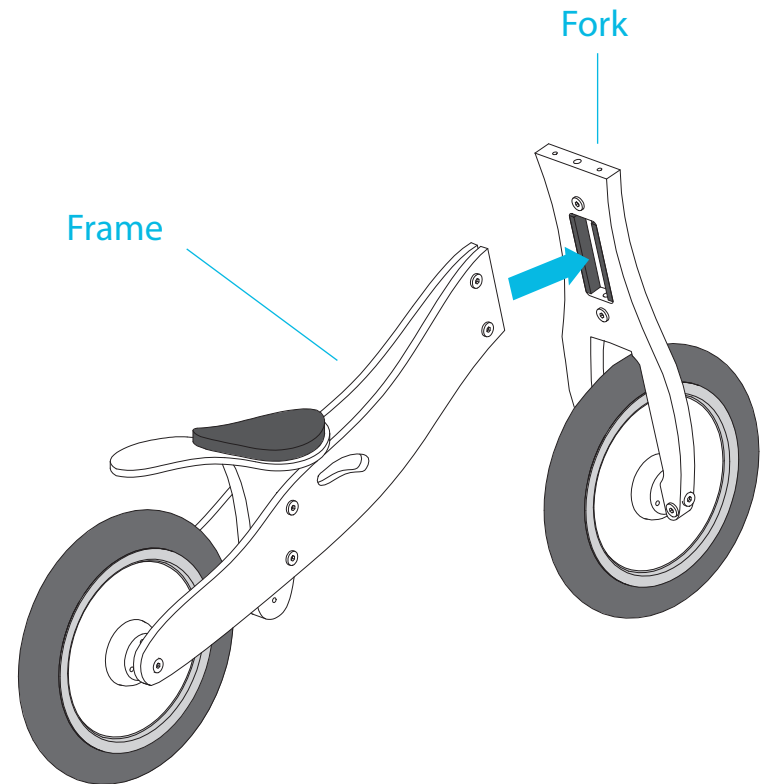

The Rookie Bike has been pre-assembled with the seat in the lowest position for a beginner rider. Position the frame and fork of the bike together.

# Rookie Bike

## Assembly Instructions

mocka

3

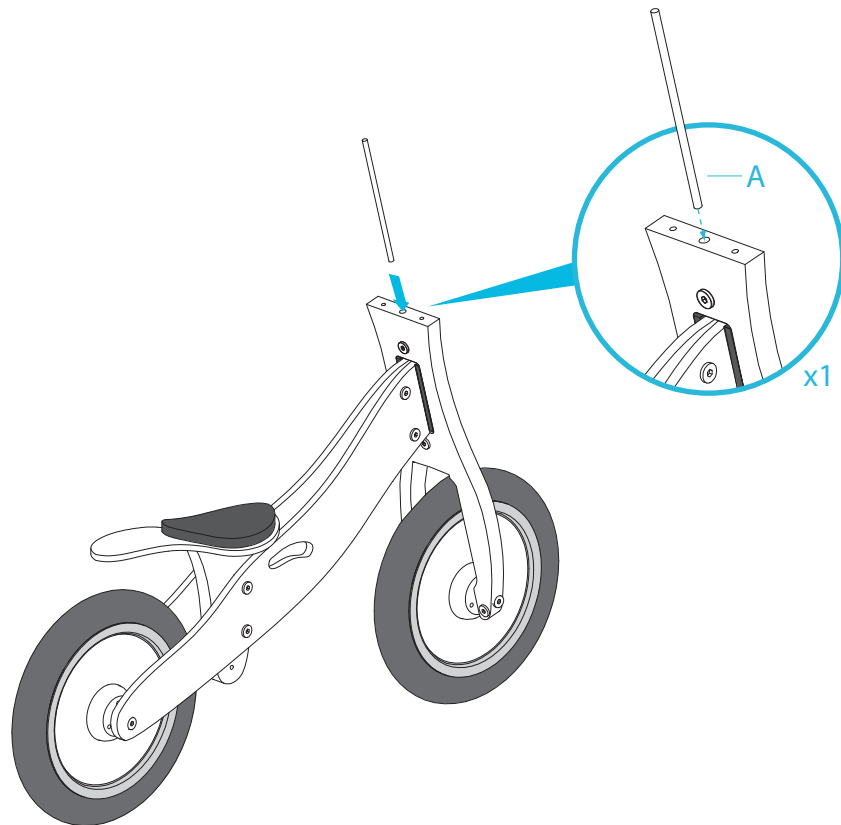

Connect the frame and fork using the steering axle rod (A). Slide the rod down into the central hole in the top an through the end of the frame.

4

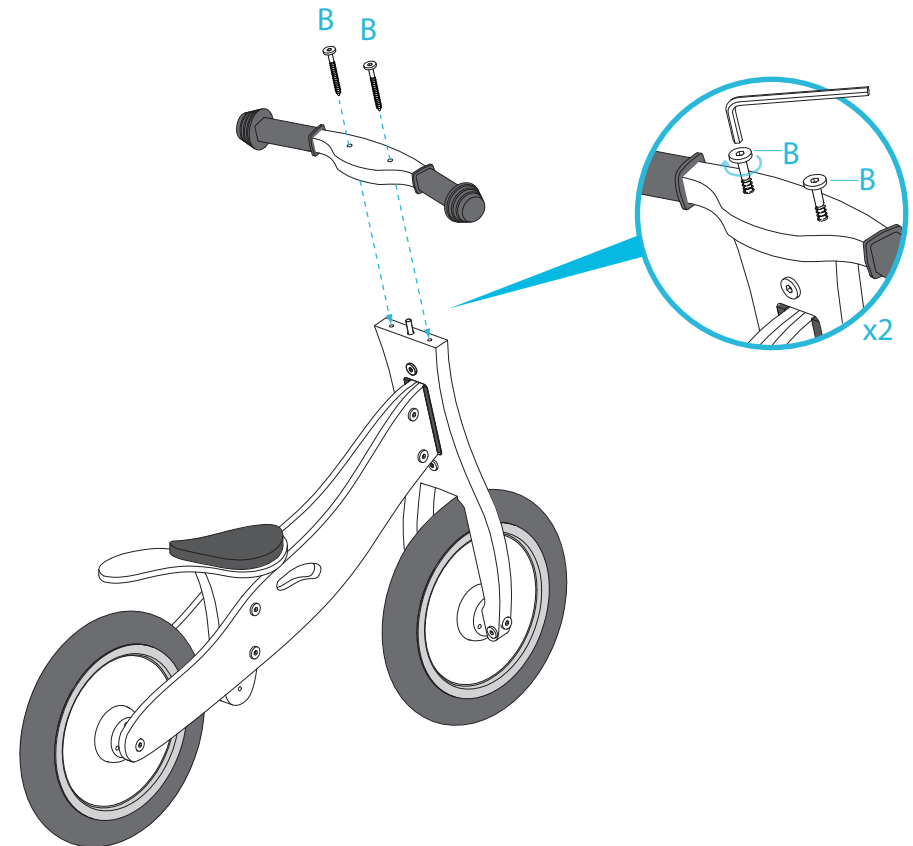

Using the two long screws (B), attach the handle bars to the top of the steering section. Tighten both screws securely with the Allen key (D).

# Rookie Bike

## Assembly Instructions

mocka

5

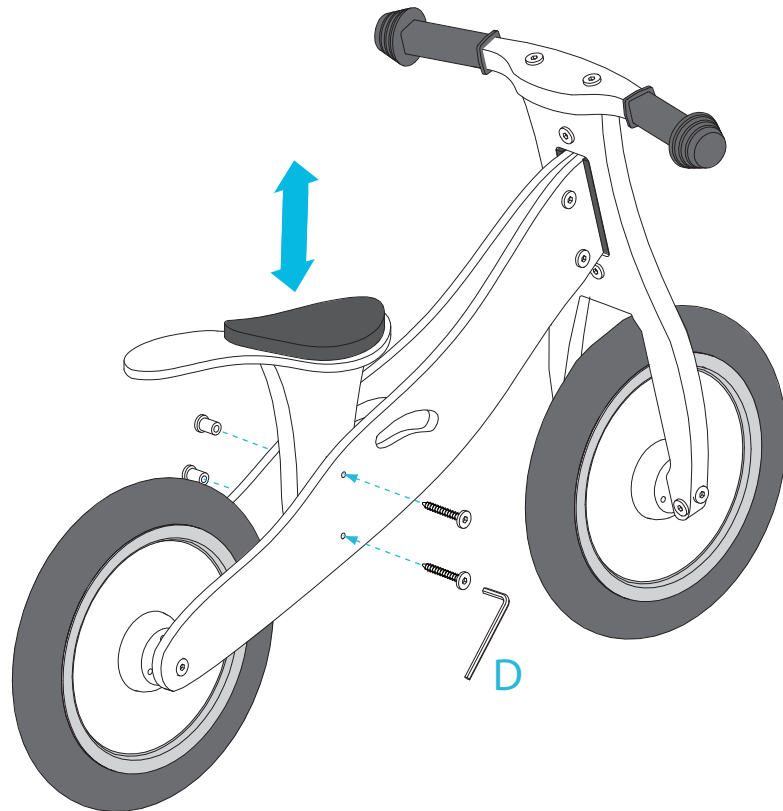

Use allen key (D) to release and re-tighten the pre-assembled screws and bolts to adjust the seat.

6



All done! We are confident your child will have years of fun and adventure while developing fantastic balance and co-ordination skills!